

Wet & Dry vacuum cleaner - Aspiradores de polvo e líquido - Aspirateurs por líquides

EN SPARE PARTS CATALOGUE
FR CATALOGUE DE PIÈCES DÉTACHÉES
ES CATALOGO PIEZAS DE REPUESTO

HILLYARD
®

TRIDENT
®

by HILLYARD



ORIGINAL INSTRUCTIONS DOC. 10076077 - Ver. AE - 09-2019

SUMMARY

SUMMARY	3
RULES	4
PRODUCT STRUCTURE.....	6
HEAD GROUP	8
FLOATING GROUP	10
TANK UNIT	12
ACCESSORIES	14
SQUEEGEE GROUP	16

SOMMAIRE

SOMMAIRE.....	3
RÈGLES.....	4
STRUCTURE DU PRODUIT	6
GROUPE TESTÉ	8
GROUPE FLOTTANT	10
UNITÉ DE TAMBOUR.....	12
ACCESSOIRES	14
GROUPE RACLETTE.....	16

ÍNDICE

ÍNDICE	3
REGLAS.....	4
ESTRUCTURA DEL PRODUCTO	6
GRUPO PROBADO	8
GRUPO FLOTANTE	10
UNIDAD DE TAMBOR.....	12
ACCESORIOS	14
GRUPO DE RASERO.....	16

EN - The contained descriptions in the present publication are not binding. The Manufacturer therefore reserves itself the right to bring in whatever moment possible organs changes, details or supplies of accessories, that it holds convenient for an improvement, or for any demand of constructive or commercial character. The partial reproduction of the texts and diagrammes contained in the present catalog, is forbidden by law. The Manufacturer reserves itself the right to bring changes of technical character and/or of endowment. The images are meant of pure reference and not binding in terms of design and endowment.

INTRODUCTION:

This catalogue is intended to serve as a guide for the ordering of spare parts and is designed to facilitate rapid identification of the machine in all its versions and to rapid location of its component parts.

HOW TO ORDER:

For the purpose of simplifying stock searching and the delivery of spare parts, we would ask our customers to observe the following standard procedures, at all times specifying:

- The model and part number of the machine;
- The position number and the number of the table of chart in which the parts appear;
- Ordering code and part name;
- Quantity of parts required;
- Precise address and company status of the purchaser placing the order, complete with address for delivery of the goods;
- Shipping means required.

FR - Les descriptions contenu dans la présente publication ne s'entendent pas contraignant. Le Fabriquant donc, il se réserve le droit d'apporter dans n'importe quel moment, les modifications éventuelles à organes, détails, fournitures d'accessoires, qu'elle croit convenables pour une amélioration ou pour n'importe quel exigence de caractère constructif ou commercial.

La reproduction partielle aussi des textes et des dessins, contenu dans le présent catalogue, elle est prohibée aux termes de la loi. Le Fabriquant se réserve le droit d'apporter modifications de caractère technique et/ou de dotation. Les images sont à s'entendre en référence pure et pas contraignants en termes de design et dotation.

INTRODUCTION:

Le présent catalogue a pour but de guider l'utilisateur dans les commandes de pièces détachées. Il a été réalisé pour faciliter une identification rapide de la machine dans toutes ses versions et permet ainsi un repérage rapide de ses composants.

COMMENT PASSER COMMANDE:

Afin de simplifier la recherche dans le magasin et l'expédition des pièces de rechange, nous prions notre clientèle de respecter la procédure suivante en indiquant toujours:

- Le modèle et numéro de la machine;
- Le numéro de la position et numéro du tableau sur lequel figure la pièce;
- La référence et la dénomination;
- La quantité des pièces demandées;
- L'adresse exacte et la raison sociale de l'acheteur qui passe la commande, en indiquant l'adresse de livraison;
- Le moyen de transport désiré (dans le cas où ceci n'est pas précisé l'expéditeur se réserve le droit de choisir le transporteur).

ES - Las descripciones contenidas en la presente publicación no son empeñativas. La Empresa por lo tanto se reserva el derecho de aportar en cualquier momento, eventuales modificaciones a órganos, detalles, suministros de accesorios, que ella crea conveniente para una mejoría o por cualquier exigencia de carácter constructivo o comercial. La reproducción parcial de

los textos y los diseños, contenidos en el presente catálogo, está prohibida por la ley. La Empresa se reserva el derecho a aportar modificaciones de carácter técnico e/o de dotation. Las imágenes son de pura referencia y no vinculantes en términos de diseño y dotation.

INTRODUCCIÓN:

Ese catálogo quiere servir cómo guía para pedir las piezas de repuesto y se ha realizado de manera de consentir una rápida identificación de la máquina en todas sus versiones y por consiguiente una rápida individuación de las piezas que la componen.

MODALIDADES DE LOS PEDIDOS:

Para la búsqueda en el almacén y el envío de las piezas de repuesto, se ruega encarecidamente a los Sres. Clientes de seguir las reglas siguientes y de especificar siempre:

- El modelo y el número de matrícula de la máquina;
- El número de posición y el número de la tabla donde son representadas;
- El código de pedido y la denominación;
- El número de piezas que se desean;
- Las señas exactas y la razón social del Comitente, indicando también las señas eventuales para la entrega de la mercancía;
- El medio de envío que se desea. (En caso de que ese dato no se haya especificado, la Empresa Constructora se reserva el derecho de utilizar a su elección el medio más adecuado).

UPDATES FROM THE PREVIOUS VERSION:

- = This document is valid since the serial number.
- ← = This document is valid till the serial number.

MISE À JOUR DE LA VERSION PRÉCÉDENTE:

- = Document valable à partir du numéro de série.
- ← = Document annulé par le numéro de série.

ACTUALIZACIÓN DE LA VERSIÓN ANTERIOR:

- = Documento válido desde la matrícula n°.
- ← = Documento válido hasta la matrícula n°.

	PAG.	N. DOC.	VER.	SERIAL NUMBER
←	18	10075979	AA	319025557
→	16	10088286	AA	319025558

CR-00 TRIDENT WD21V 120V 50HZ U

PRODUCT STRUCTURE
STRUCTURE DU PRODUIT
PRODUKTSTRUKTUR
ESTRUCTURA PRODUCTO

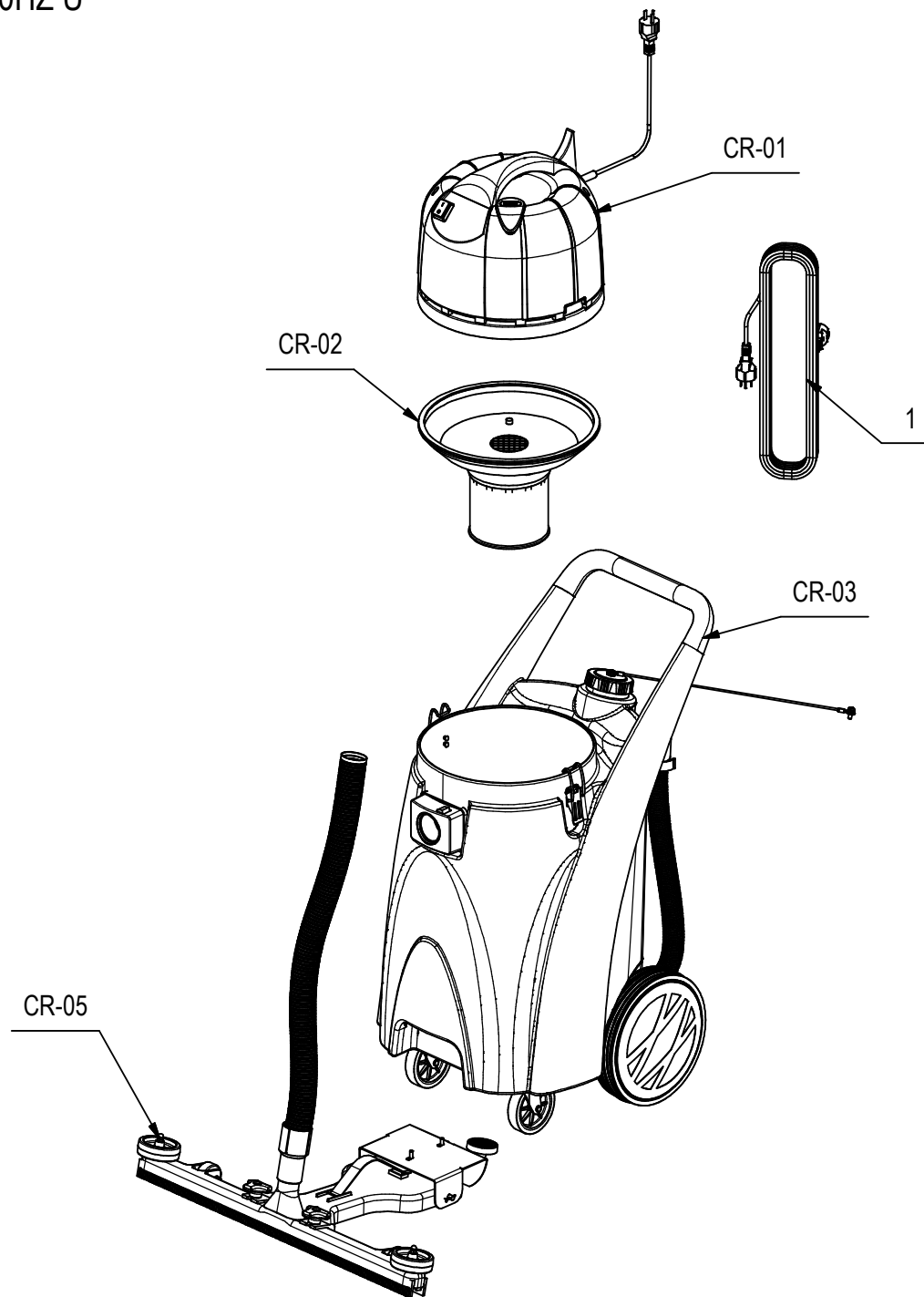

CR-00 TRIDENT WD21V 120V 50HZ U

00

POS	CODICE	QTÀ	DESCRIZIONE	DENOMINATION	DESCRIPTION	BENENNUNG	DESCRIPCION
1	447269	1	CAVO PROL.GIALLO 15MT PRESA USA+SP. USA	CABLE SJTW 3X14AWG 105D GREY PLUG USA	CABLE SJTW 3X14AWG 105D GREY PLUG USA	CAVO SJTW 3X14AWG 105D GREY PLUG USA 15M	CABLE SJTW 3X14AWG 105D GREY PLUG USA
CR-01	227479	1	GRUPPO TESTATA WD21V 1100W 115V US	VACUUM GROUP 1100W 115V US	GROUPE D'ASPIRATION 1100W 115V US	VACUUM GROUP 1100W 115V US	GRUPO ASPIRANTE 1100W 115V US
CR-02	217802	1	GRUPPO GALLEGGIANTE QUICK LINE	FLOATING	FLOTTANT	KOMMA	FLOTANTE
CR-03	227480	1	GRUPPO FUSTO HILLYARD 80L BLU RAL 5012	TANK GROUP	RESERVOIR	BEHALTERKOMPLETT	TANQUE
CR-04	217801	1	KIT ACCESSORI QUICK LINE Ø 40	ACCESSORY KIT	KIT D'ACCESSOIRE	ZUBEHÖR-KIT	KIT DE ACCESSORIOS
CR-05	229227	1	SQUEEGEE IN PLASTICA COMPLETO L.720 WD21/	SQUEEGEE	SQUEEGEE	SQUEEGEE	SQUEEGEE

CR-01 GR. TESTATA WD21V 1100W 115V US

ENGINE HEAD
MOTOR HEAD
MOTOR HEAD
MOTOR PROBADO

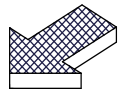
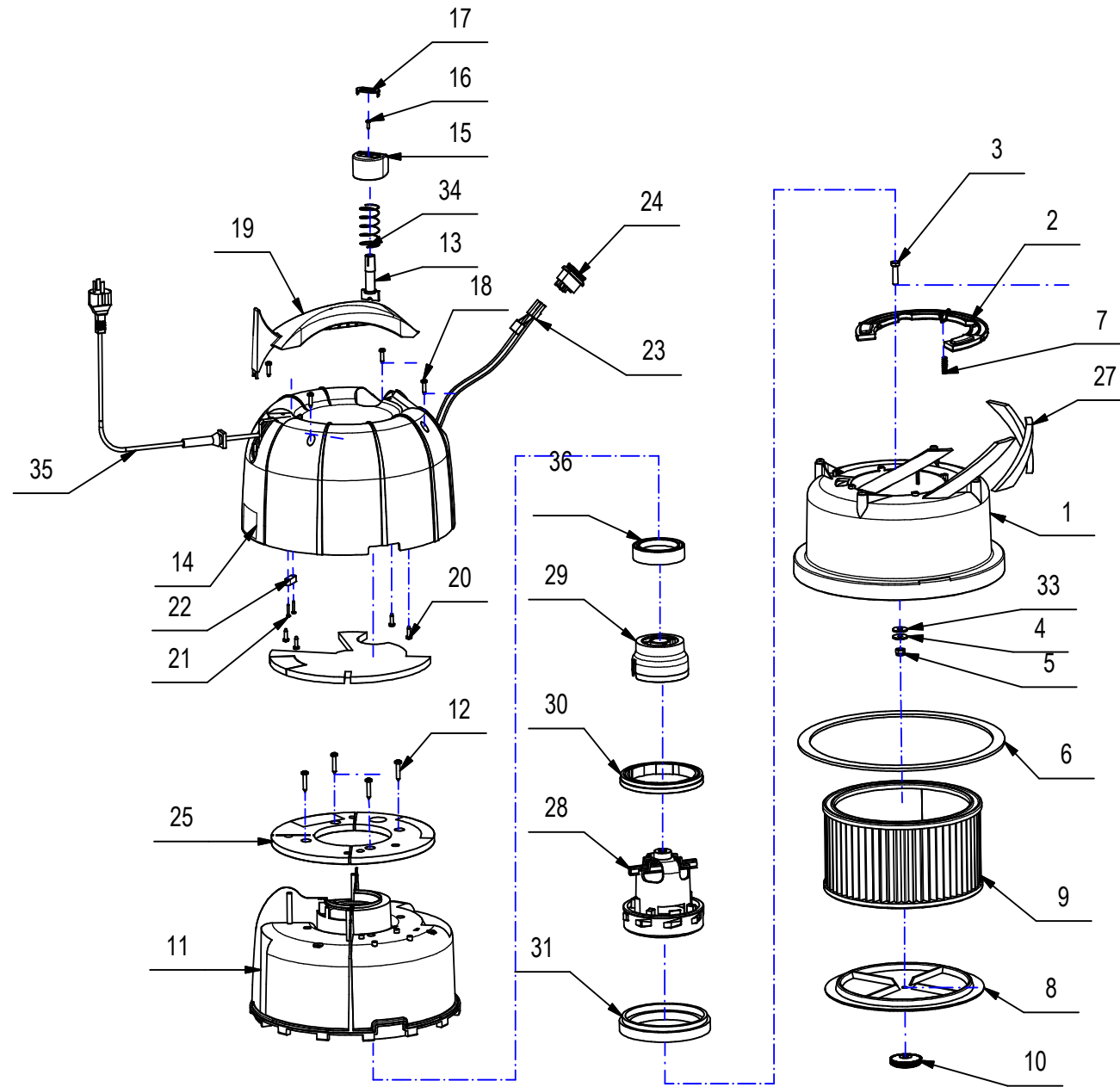

CR-01 GR. TESTATA WD21V 1100W 115V US

01

POS	CODICE	QTÀ	DESCRIZIONE	DENOMINATION	DESCRIPTION	BENENNUNG	DESCRIPCION
1	428198	1	BASAMENTO TESTATA QUICK RAL 7016	BASE	BASE	UNTERLAGE	BASE
2	428194	1	ANELLO BASCULANTE QUICK RAL 7000	RING	ANNEAU	RING	ANILLO
3	408677	1	VITE M8X30 TE UNI 5739 A2	SCREW	VIS	SCHRAUBE	TORNILLO
4	417996	1	RONDELLA D.6x24 GOMMA NERA	WASHER	RONDELLE	UNTERLAGSCHEIBE	ARANDELA
5	409087	1	DADO M8 AUTOBL. UNI 7474 INOX BASSO	LOCK NUT	ECROU AUTOFREINES	SICHERUNGSMUTTER	TUERCA AUTOBLOCANTE
6	412463	1	GUARNIZIONE BASAMENTO MOTORE CL-TOP	GASKET MOTOR BASE CL/TOP	JOINT	DICHTUNG	JUNTA
7	430832	1	MOLLA A COMPRESSIONE D.7xL.25mm	SPRING	RESSORT	FEDER	RESORTE
8	428202	1	FONDELLO FILTRO QUICK LINE RAL 7000	SUPPORT FILTER	SUPPORTE FILTRE	SUPPORT FILTER	SUPORTO DE FILTRO
9	428244	1	FILTRO CARTUCCIA BIA Di=222 De=260 H=134	FILTER	FILTRE	FILTER	FILTRO
10	418341	1	VOLANTINO DI BLOCCAGGIO M8 D=50 SP=12	HANDWHEEL	VOLANT	HANDGRIFF	RUEDA DE MANIOBRA
11	439362	1	ANELLO INTERMEDIO QUICK LINE RAL 7016	RING	ANNEAU	RING	ANILLO
12	424884	4	VITE D.5x30 TCTC AUT. PANEL-VIT NERA ZIN	SCREW	VIS	SCHRAUBE	TORNILLO
13	428195	1	ASTA PULSANTE QUICK LINE RAL 7000	ROD	TIGE	STANGE	VARILLA
14	439360	1	COPERCHIO TESTATA QUICK LINE RAL 7016	COVER	COUVERCLE	DECKEL	TAPA
15	439363	1	PULSANTE QUICK LINE RAL 1018	PUSH BUTTON	BOUTON POUSSOIR	DRUCKKNOPF	PULSADOR
16	418272	1	VITE D.3,5x13 TCTC AUTOF. UNI 6954 ZINC	SCREW	VIS	SCHRAUBE	TORNILLO
17	439390	1	COPRIVITE PULSANTE QUICK RAL 1018	SCREW COVER	COUVERCLE	SCHRAUBDECKEL	TAPA
18	418279	4	VITE D.4,8x19 AUTOF. TCTC SPUNT.NERA	SELF-TAPPING SCREW 4,8x19 SP	VIS	SCHRAUBE	TORNILLO
19	439361	1	MANIGLIA TESTATA QUICK LINE RAL 5012	HANDLE	MANCHE	HANDGRIFF	MANILLA
20	418277	4	VITE D.4,8x16 TCTC AUTOF. SPUNT. NERA	SELF-TAPPING SCREW	VIS	SCHRAUBE	TORNILLO
21	418269	2	VITE D.2,9x19 AUTOF. ZINC UNI 6954	SELF-TAPPING SCREW 2,9x19	VIS	SCHRAUBE	TORNILLO
22	409765	1	PRESSACAVO A PONTICELLO	CABLE GRIP	PRESSE-ETOUPE	KABELVERSCHRAUBUNG	RACOR CABLE
23	416994	1	CABLAGGIO MOTORE DRY SILENT	WIRING MOTOR	CÂBLAGE MOTEUR	VERKABELUNG MOTOR	CABLEADO MOTOR
24	417622	1	INTERRUPTORE BIPOLARE NERO A SOFFIETTO	BLACK BIPOLAR SWITCH	INTERRUPTEUR	SCHALTER	INTERRUPTOR
25	428661	1	FIREFLEX INTERMEDIO TESTATA QUICK	FIREFLEX	FIREFLEX	FIREFLEX	FIREFLEX
26	428662	1	FIREFLEX COPERCHIO TESTATA QUICK	FIREFLEX	FIREFLEX	FIREFLEX	FIREFLEX
27	428663	6	1/6 di FIREFLEX BASAMENTO TESTATA QUICK	FIREFLEX	FIREFLEX	FIREFLEX	FIREFLEX
28	417802	1	MOTORE MON.BYPASS-115V-CL2-1100W-HV	ENGINE	MOTEUR	MOTOR	MOTOR
29	428191	1	SEP. FLUSSI IN-OUT SPAZZOLE HV RAL 7000	SEPARATION OF FLUIDS	SEPARATION DES FLUIDES	SEPARATOR	SEPARADOR
30	428192	1	GUARNIZ. ANELLO INTERMEDIO-MOTORE A.V.	GASKET	JOINT	DICHTUNG	JUNTA
31	417560	1	GUARNIZIONE MOTORE ALTA VELOCITA' SP=10	GASKET	JOINT	DICHTUNG	JUNTA
33	418000	1	RONDELLA D.8x24 INOX DIN 9021 - A2	WASHER	RONDELLE	UNTERLAGSCHEIBE	ARANDELA
34	430854	1	MOLLA COMPRESSIONE L.60x d.int 30xSP.1mm	SPRING	RESSORT	FEDER	RESORTE
35	227588	1	CAVO CABL. 3xAWG14x0.73M SJTW SPINA USA	CABLE	CABLE	KABLE	CABLE
36	417558	1	GUARNIZIONE MOTORE AL T	COVER SHOULDER	JOINT	DICHTUNG	JUNTA

CR-02 GRUPPO GALLEGGIANTE QUICK LINE

FILTER ASSEMBLY
FILTRE COMPLET
FILTER KOMPLETT
FILTRO COMPLETO

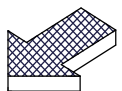
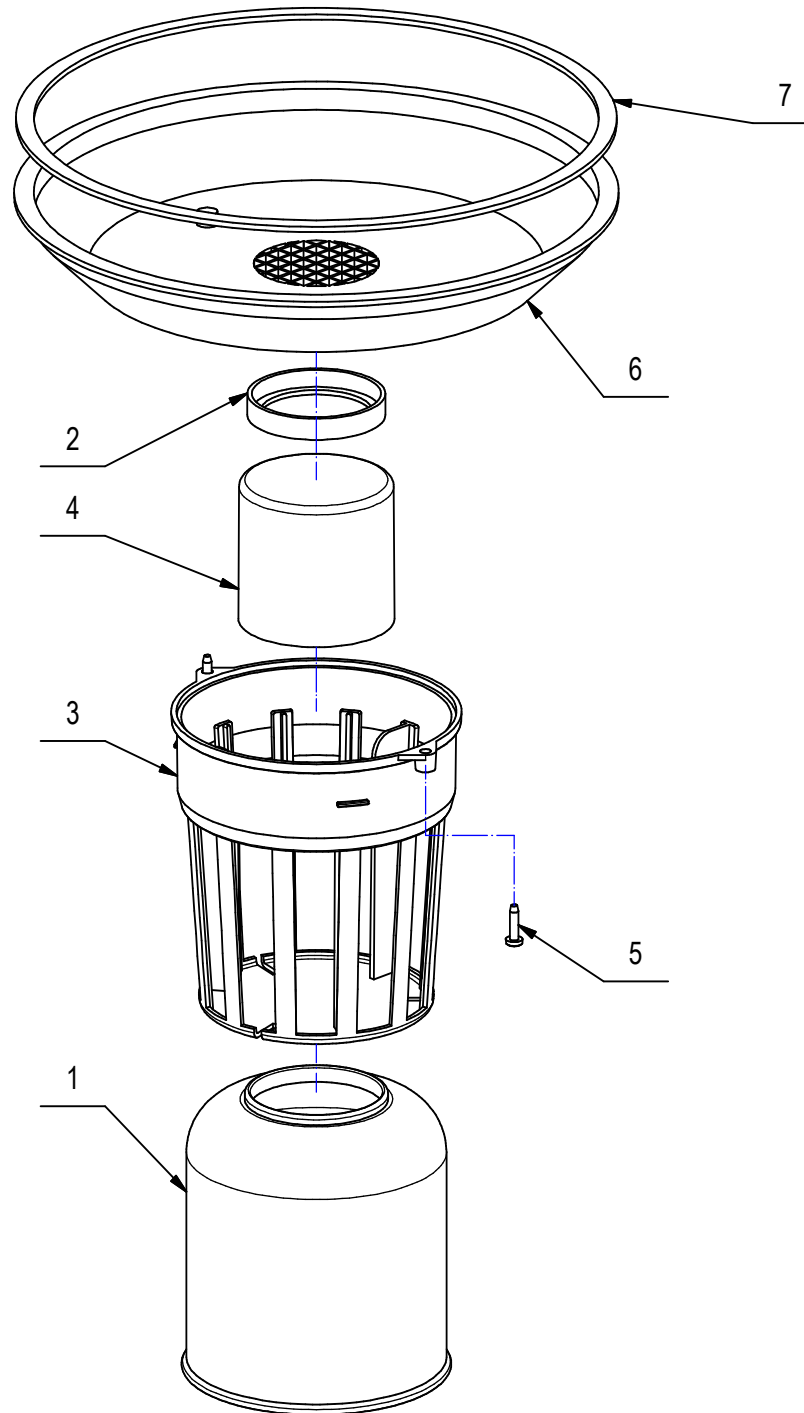

CR-02 GRUPPO GALLEGGIANTE QUICK LINE

02

POS	CODICE	QTÀ	DESCRIZIONE	DENOMINATION	DESCRIPTION	BENENNUNG	DESCRIPCION
1	405429	1	FILTRO SPUGNA PER ACQUA	SPONGE FILTER x WATER	FILTRE	FILTER	FILTRO
2	405946	1	GUARNIZIONE GALLEGGIANTE B270	GASKET	JOINT	DICHTUNG	JUNTA
3	417138	1	CESTELLO TENDIFILTRO IN PLASTICA	FLOAT CAGE	PORTE-FILTRE	FILTERTRÄGER	PORTAFILTRO
4	417501	1	GALLEGGIANTE D.87 BIANCO	WHITE FLOAT I87	FLOTTEUR	SCHWIMMER	FLOTADOR
5	418279	2	VITE D.4,8x19 AUTOF. TCTC SPUNT.NERA	SELF-TAPPING SCREW	VIS	SCHRAUBE	TORNILLO
6	428201	1	ANELLO PORTAFILTRO QUICK LINE RAL 7000	SUPPORT	SUPPORT	HALTERUNG	SOPORTE
7	410779	1	PROFILO MOUSSE SEZ.10X3 ADESIVO	MOUSSE SEZ.10X3	MOUSSE SEZ.10X3	MOUSSE SEZ.10X3	MOUSSE SEZ.10X3

CR-03 GRUPPO FUSTO HILLYARD 80L RAL 5012

TANK
RESERVOIR
TANK
TANQUE

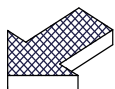
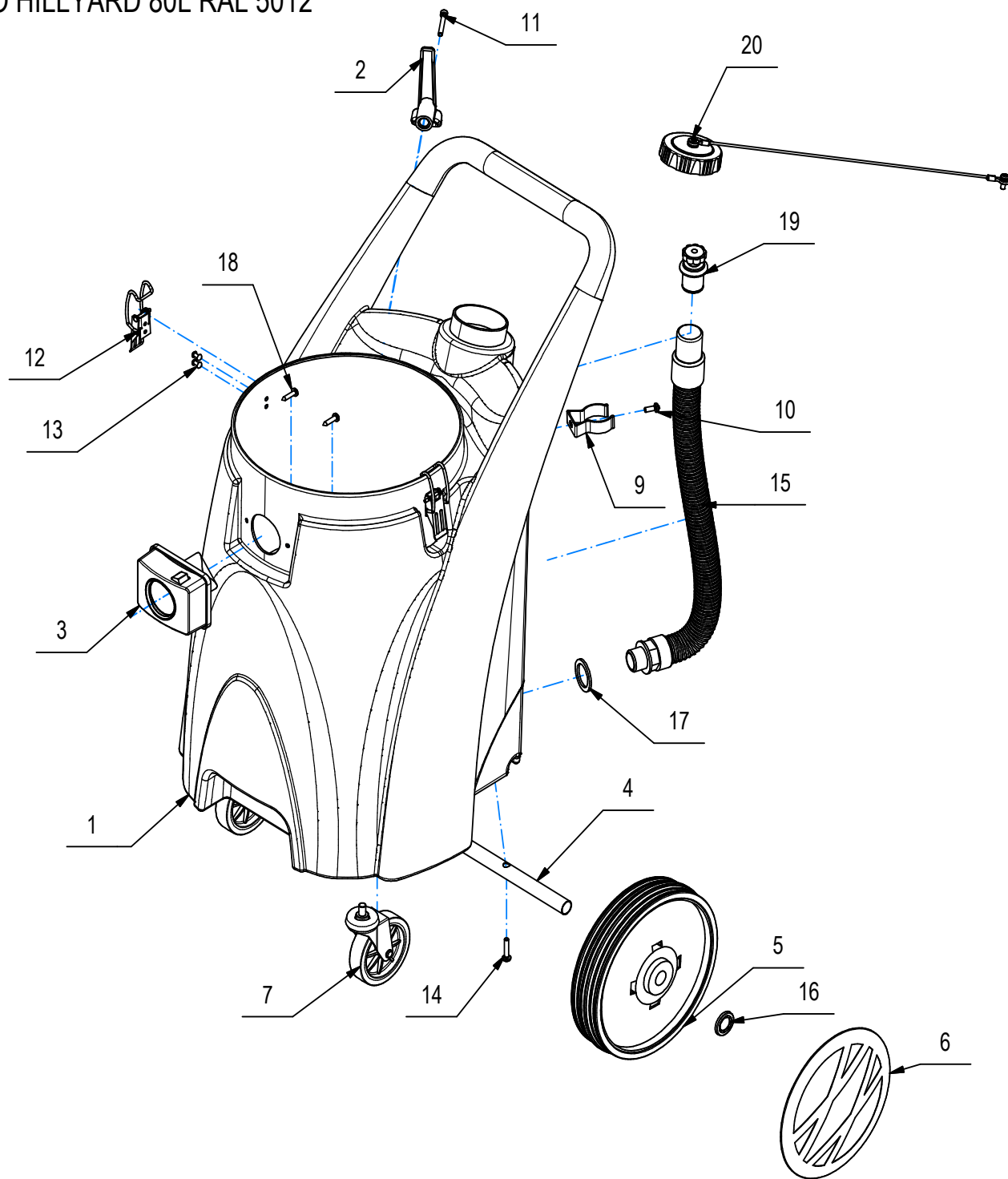

CR-03 GRUPPO FUSTO HILLYARD 80L RAL 5012

03

POS	CODICE	QTÀ	DESCRIZIONE	DENOMINATION	DESCRIPTION	BENENNUNG	DESCRIPCION
1	417644	1	INVOLUCRO 80L BLU RAL 5012	TANK	RESERVOIR	TANK	TANQUE
2	416543	1	MANIGLIA PORTACAVO	SUPPORT	SUPPORT	HALTERUNG	SOPORTE
3	412464	1	BOCCHETTA COMPL.D40 RAL 9002 TASTO ROSSO	OPENING	BUSE	ÖFFNUNG	BOQUILLA
4	416867	1	ASSALE RUOTA D.20 ZNT X CA80/ 100	SHAFT	ARBRE	WELLE	EJE
5	418014	2	RUOTA D.250-GRIGIA-F.P.D.20 ART.SP25020	WHEEL	ROUE	RAD	RUEDA
6	417186	2	COPERCHIO RUOTA D.250 NERO	COVER	COUVERCLE	DECKEL	TAPA
7	418026	2	RUOTA PIROETTANTE D.100 PERNO M10x15	WHEEL	ROUE	RAD	RUEDA
8	410542	2	INSERTO M6x14	INSERT	SUPPLEMENT	BEILAGE	LEGAJO
9	412123	1	CLIP ABS FISSAGGIO TUBO D=38	SPRING	RESSORT	FEDER	RESORTE
10	408860	1	VITE M6x16 TCTC UNI 7687 ZINC	SCREW	VIS	SCHRAUBE	TORNILLO
11	408807	1	VITE M6x45 TCEI UNI 5931 FP ZINC	SCREW	VIS	SCHRAUBE	TORNILLO
12	417504	2	GANCIO CHIUSURA ACC. TESTA-FUSTO NERO	HOOK	CROCHET	HAKEN	GANCHO
13	409360	4	RIVETTO 4,8x14 ALLUMINIO	RIVET	RIVET	NIET	CLAVO
14	408857	2	VITE M6x30 TCTC UNI 7985 ZINC	SCREW	VIS	SCHRAUBE	TORNILLO
15	418208	1	TUBO DI SCARICO+MANICOTTI D.32 x FA100	EXHAUST PIPE	FLEXIBLE DE VIDANGE	ABWASSERSCHLAUCH	TUBO DE DESCARGA
16	418140	2	STARLOOK D.20mm	STARLOOK D. 20MM	BOUCHON RING D. 20MM	Anschlagring D.20MM	ANILLO DE TOPE
17	417554	1	GUARNIZIONE GOMMA 1" TUBO SCARICO	GASKET	JOINT	DICHTUNG	JUNTA
18	418287	2	VITE D.4.8x25 AUTOF. TCTC NERA PANEL-VIT	SELF-TAPPING SCREW	VIS	SCHRAUBE	TORNILLO
19	418167	1	TAPPO TUBO SCARICO PL COMPLETO AD ESPANS	COVER	COUVERCLE	DECKEL	TAPA
20	231202	1	TAPPO CON CORDINO	STROPPER	BOUCHON	STOPPER	TAPON



CR-04 ACCESSORI/ACCESSORIES

04

POS	CODICE	QTÀ	DESCRIZIONE	DENOMINATION	DESCRIPTION	BENENNUNG	DESCRIPCION
1	440262	1	VENTOSA LIQUIDI D.40 (VERSIONE 2014)	LIQUID BRUSH	BROSSE LIQUIDE	FLÜSSIG BÜRSTE	CEPILLO LIQUIDO
2	401070	1	SPAZZOLA SETOLE D.40	BRUSH	BROSSE	BÜRSTE	CEPILLO
3	401069	1	COPPIA PROLUNGA S D.40CROMATA	EXTENSION TUBE	TUBE D'EXTENSION	VERLÄNGERUNGSSTÜCK	TUBO DE EXTENSION
4	401072	1	PROLUNGA PLASTICA D.40X500	EXTENSION PLASTIC	EXTENSION EN PLASTIQUE	EXTENSION PLASTIC	EXTENSIÓN DE PLÁSTICO
5	401068	1	TUBO FLEX D.40 COMPL.DA M.2.50	FLEX 2,5M	FLEX 2,5M	FLEX 2,5M	FLEX 2,5M
6	401024	1	LANCIA PIATTA D.40	CREVICE	EMBOUT PLAT	FUGENDUSE	LANCIA PISO
7	401026	1	PENNELLO SETOLE D.40	BRUSH	BROSSE	BÜRSTE	CEPILLO
8	440359	1	Replacement Blades for Squeegee Tool				

CR-05 SQUEEGEE PLASTICA COMPLETO L.720

PRODUCT STRUCTURE
STRUCTURE DE PRODUIT
PRODUKTSTRUKTUR
ESTRUCTURA DEL PRODUCTO

** Note: Depending on stock single hose 418232 may be replaced by assembly of 3 parts: 400999, 412455 & 400991

** Click Below for video **

KIT: HIL232587 Upgrade:

***HIL408657 bolts (4)**

***HIL409107 nuts(2)**

***HIL411768 bushings(2)**

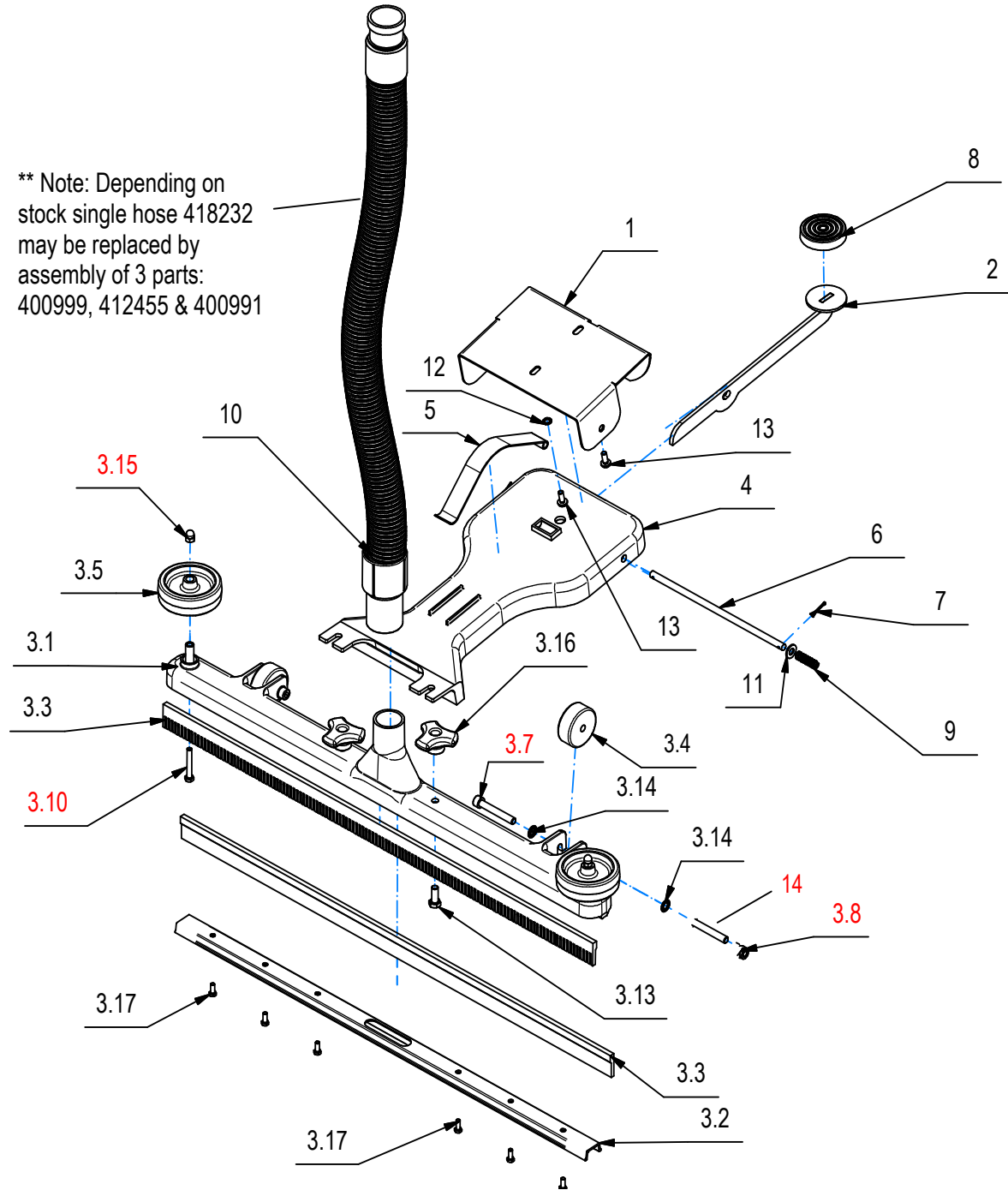

CR-05 SQUEEGEE PLASTICA COMPLETO L.720

05

POS	CODICE	QTÀ	DESCRIZIONE	DESCRIPTION	DESIGNATION	BEZEICHNUNG	DESCRPCIÓN
1	451233	1	STAFFA PORTA SQUEEGEE PLASTICA	SUPPORT BRACKET	SUPPORT DE FIXATION	STEIGBÜGEL DER UNTERSTÜTZUNG	SOPORTE DE FIJACION
2	451234	1	PEDALE SQUEEGEE PLAST. WD21/P80	PEDAL	PEDALE	PEDAL	PEDAL
3.1	450023	1	CORPO SQUEEGEE L.720 D.38 PLASTICA	SQUEEGEE BODY	CORPS DE SUCEUR	SAUGFUSSKÖRPER	CUERPO LIMPIAPAVIMENTOS
3.2	456695	1	PROFILO BLOCCA LISTELLI	LOCK STRIPES PROFIL	PROFILE DU BLOCAGE	BLOCKLISTENPROFIL	PERFIL DE BOQUES
3.3	450033	2	LISTELLO SQUEEGEE L.718	SQUEEGEE STRIP	BANDE DE RACLOIR	SQUEEGEE-STREIFEN	BANDA PARA SQUEEGEE
3.4	450528	2	RUOTA 50x20	WHEEL	ROUE	RAD	RAD
3.5	418021	2	RUOTA FISSA DIAM.80 + BUSSOLA 10x1,5x29	WHEEL	ROUE	RAD	RAD
3.7	408657	2	VITE M8x55 TCEI UNI 5931 A2	SCREW	VIS	SCHRAUBE	TORNILLO
3.8	409107	2	DADO M8 AUTOBL. UNI 7473 A2	LOCK NUT	ECROU AUTOBLOQUANT	STOPMUTTER	TUERCA AUTOBLOCANTE
3.10	408657	2	VITE M6x40 TE UNI 5739 A2	SCREW	VIS	SCHRAUBE	TORNILLO
3.13	408671	2	VITE M8x20 TE UNI 5739 A2	SCREW	VIS	SCHRAUBE	TORNILLO
3.14	450968	4	RONDELLA D.8x17 DENTEL.INT A2	WASHER D.8X17	LAVE D.8X17	SCHEIBE D.8X17	LAVADORA D.8X17
3.15	409107	2	DADO M6 CIECO CON CALOTTA UNI 5721 INOX	DOMED CAP NUT	ECROU BORGNE	HUTMUTTER	TUERCA
3.16	448820	2	MANOPOLA DI BLOCCO PARASPR. BMG	KNOB	POIGNEE	HANDGRIFF	EMPUÑADURA
3.17	450967	6	VITE M5x10 TE UNI 5739 A2	SCREW	VIS	SCHRAUBE	TORNILLO
4	450025	1	STAFFA SUPPORTO SQUEEGEE PLASTICA	SUPPORT	ATTAQUE	HALTERUNG	SOPORTE FIJADOR
5	450387	1	MOLLA PER SQUEEGEE	SPRING FOR SQUEEGEE	RESSORT	FEDER	RESORTE
6	457635	1	PERNO SQUEEGEE	AXLE	AXE	STIFT	EJE
7	409382	2	COPIGLIA D2 X20 UNI 1336	SPLIT PIN	GOUPILLE	SPLINT	PASADOR DE ALETAS
8	417532	1	GOMMINO PEDALE SQUEEGEE	COVERAGE PEDAL RUBBERIZES	COUVERTURE PÉDALE GOMME	ERFASSUNGSPEDAL GUMMIERT	COBERTURA PEDAL ENGOMA
9	416725	1	MOLLA ASTA SGANCIO MANUBRIO	SPRING	RESSORT	FEDER	RESORTE
10	418232	1	TUBO RACCORDO D=40 ACC. FISSO+MAN.	SUCTION HOSE	FLEXIBLE ASPIRATION	SAUGSCHLAUCH	TUBO DE ASPIRACION
11	409177	1	ROSETTA 8x17x1.6 UNI 6592 A2	WASHER	RONDELLE	SCHEIBE	ARANDELA
12	417991	2	RONDELLA D.6,4x12 DENTEL.INT-E UNI 8842	WASHER	RONDELLE	UNTERLAGSCHEIBE	ARANDELA
13	408860	2	VITE M6x16 TCTC UNI 7687 ZINC	SCREW	VIS	SCHRAUBE	TORNILLO
14	411768	2	Wheel Bushing				

CR-05 TERGIPAVIMENTO FRONTALE HILLYARD

SQUEEGEE
SQUEEGEE
SQUEEGEE
SQUEEGEE

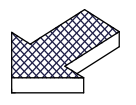
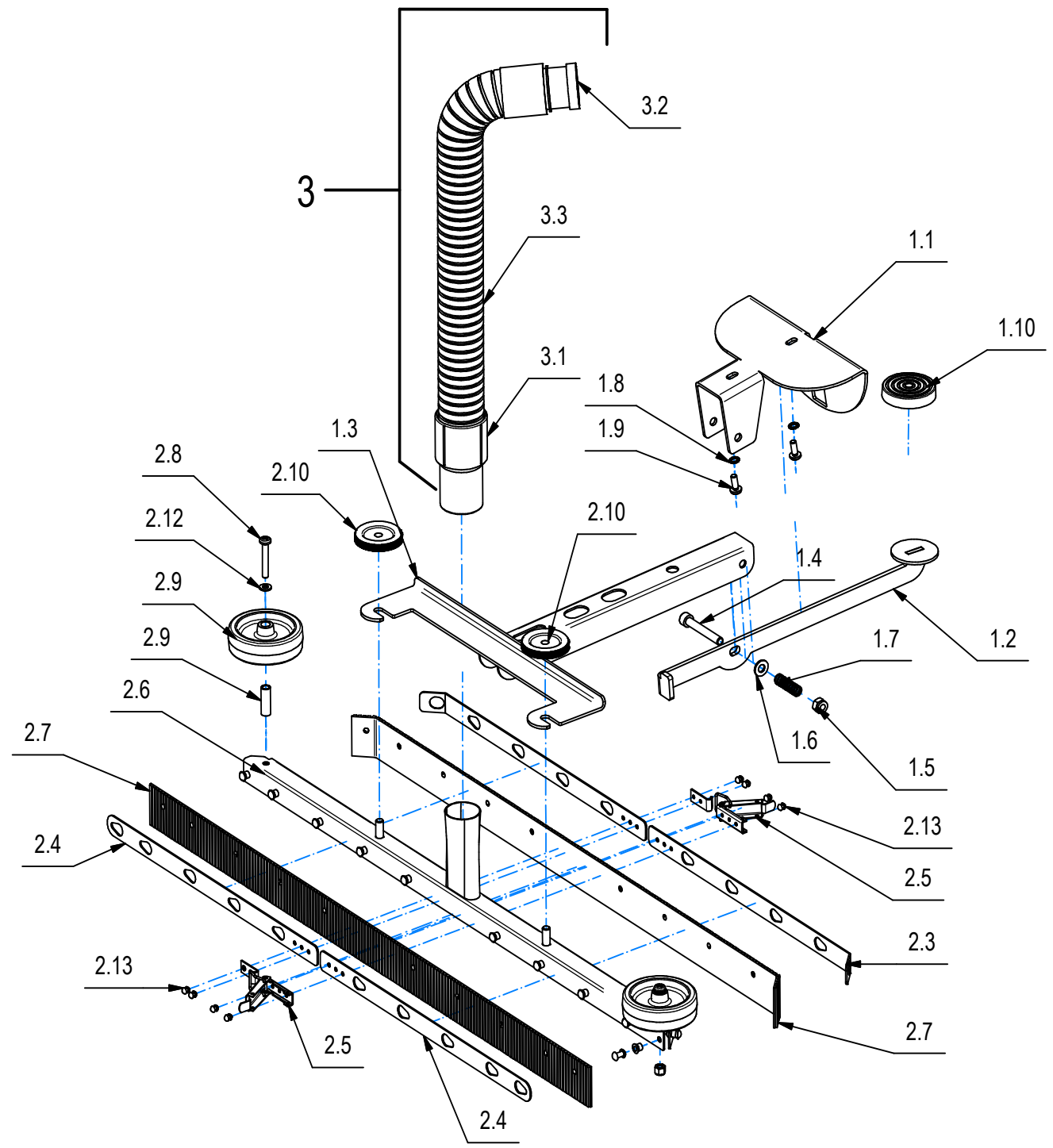

CR-05 TERGIPAVIMENTO FRONTALE HILLYARD

POS	CODICE	QTÀ	DESCRIZIONE	DENOMINATION	DESCRIPTION	BENENNUNG	DESCRIPCION
1	204573	1	GR. SUPPORTO SQUEEGEE TOP P100 CA80/100	SQUEEGEE GROUP	GROUPE SQUEEGEE	GRUPE SQUEEGEE	GRUPO SQUEEGEE
1.1	418136	1	STAFFA PORTA SQUEEGEE TOPP100 CA80/100	SUPPORT	ATTAQUE	HALTERUNG	SOPORTE FIJADOR
1.2	417832	1	PEDALE SQUEEGEE TOPP100 WD CA80/100	PEDALS	PÉDALES	PEDALE	PEDALES
1.3	418127	1	STAFFA SQUEEGEE	SUPPORT	ATTAQUE	HALTERUNG	SOPORTE FIJADOR
1.4	418300	1	VITE M8x55 TCEI UNI 5931 ZINC.	SCREW	VIS	SCHRAUBE	TORNILLO
1.5	409085	1	DADO M8x8.5 AUTOBL. UNI 7474 ZINC	LOCK NUT	ECROU AUTOFREINES	SICHERUNGSMUTTER	TUERCA AUTOBLOCANTE
1.6	417999	1	RONDELLA D.8x17 ZINCATA DIN 9021	WASHER	RONDELLE	UNTERLAGSCHEIBE	ARANDELA
1.7	417786	1	MOLLA COMPRESSIONE De=11 d=1 L=35 ZNT	SPRING	RESSORT	FEDER	RESORTE
1.8	417991	2	RONDELLA D.6,4x12 DENTEL.INT-E UNI 8842	WASHER	RONDELLE	UNTERLAGSCHEIBE	ARANDELA
1.9	418317	2	VITE M6x16 TCTC UNI 7687 ZNT	SCREW	VIS	SCHRAUBE	TORNILLO
1.10	417532	1	GOMMINO PEDALE SQUEEGEE	RUBBER	CAOUTCHOUC	GUMMI	GOMA
2	204575	1	VENTOSA FRONTALE WET L=740 COMPLETA	CUP	COUPE	CUP	VENTOSA
2.1	417286	20	DISTANZIALE BLOCCA LISTELLI GOMMA	SPACER	ENTRETOISE	ABSTANDS	ESPACIADOR
2.2	417967	20	RIVETTO 4.8x14 INOX	RIVET	RIVET	NIET	REMACHE
2.3	417714	2	LIST.PIEG.xNEW SQUEEGEE L.740 INOX 304	BLADE	PLAQUETTE	LEISTE	LISTON
2.4	417717	2	LISTELLO NEW SQUEEGEE L.740 INOX 304	BLADE	PLAQUETTE	LEISTE	LISTON
2.5	417513	2	GANCIO A LEVA CON INCONTRO CROMATO	HOOK	CROCHET	HAKEN	GANCHO
2.6	417233	1	CORPO VENTOSA V2 L=740 AISI 304	CUP	COUPE	CUP	VENTOSA
2.7	417211	1	COPPIA LISTELLI GOMMA SQUEEGEE WET L.740	BLADE	PLAQUETTE	LEISTE	LISTON
2.8	418318	2	VITE M6x40 TCTC UNI 7687 INOX	SCREW	VIS	SCHRAUBE	TORNILLO
2.9	418021	2	RUOTA FISSA DIAM.80 + BUSSOLA 10x1,5x29	WHEEL	ROUE	RAD	RUEDA
2.10	418341	2	VOLANTINO DI BLOCCAGGIO M8 D=50 SP=12	HANDWHEEL	VOLANT	HANDGRIFF	RUEDA DE MANIOBRA
2.11	409083	2	DADO M6x8 AUTOBL. UNI 7473 DIN 982 A2	NUT	ECROU	MUTTER	TUERCA
2.12	417992	2	RONDELLA D.6,4x12 INOX UNI 6592	WASHER	RONDELLE	UNTERLAGSCHEIBE	ARANDELA
2.13	417965	8	RIVETTO 3.2X7 ALLUMINIO	RIVET	RIVET	NIET	REMACHE
3	447946	1	TUBO-RACCORDO COMPL. D.40+MAN. L.610MM	TUBE D.40+MAN. L.610MM	TUBE D.40+MAN. L.610MM	ROHR D.40+MAN. L.610MM	TUBO D.40+MAN. L.610MM
3.1	400991	1	MANICOTTO IN PVC DIAM.40	FITTING	RACCORD	VERSCHRAUBUNG	RACOR
3.2	412455	1	MANICOTTO D.40 ABS LATO BOCCHETTA	MALE COUPLING	EMBRYAGE MALE	KUPPLUNG MIT ZAPFEN	ACOPLAMIENTO MACHO
3.3	400999	1	TUBO FLEX DIAM.40mm (dis. 610mm)	TUBE	TUBE	ROHR	TUBO