

B16SC



Car Dealerships



Kitchens



Tight Spaces

Better Built. Better Equipment.

Replace The Mop Bucket

Get Better Cleaning Results - Faster - with Far Less Effort!



Quick-Release
Lever Control Squeegee



Intuitive User
Control Panel



Easily Remove and
Replace Battery

Float switch for
suction motor
protection.

Onboard "plug-in"
battery charging.

Over-sized wheels
and light weight
for increased
maneuverability.

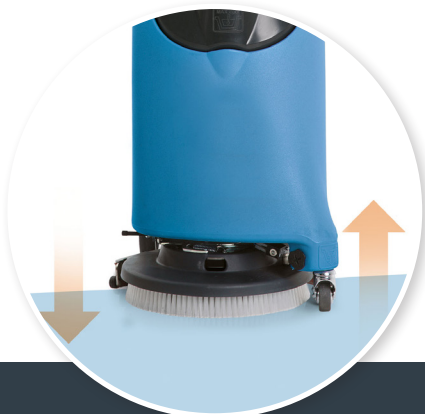
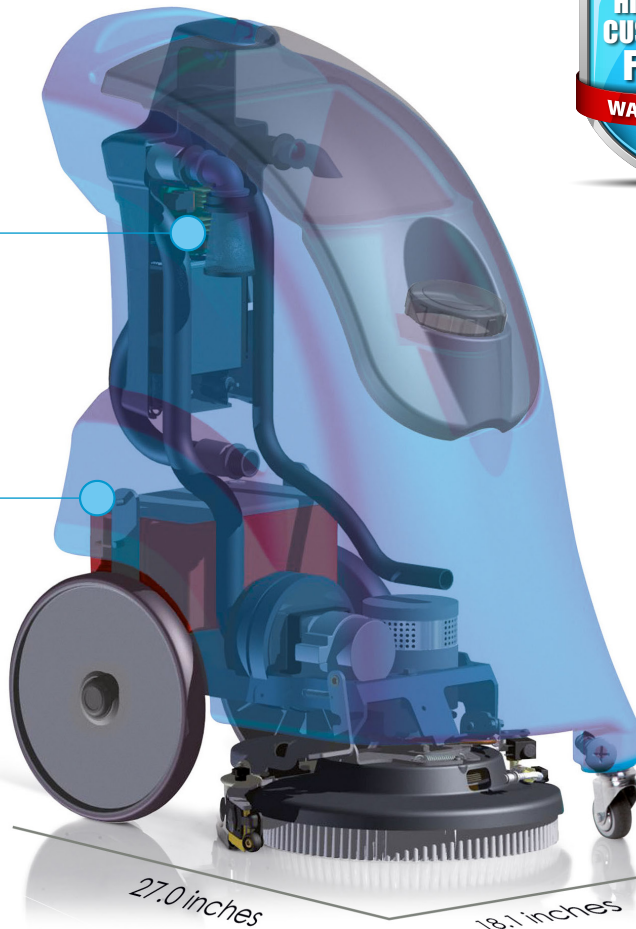

Auto Adjust

The B16 automatically
adjusts to any floor
type to deliver high-
performance cleaning.

Center Feed-Solution

Excellent drying performance
thanks to solution outflow
from the center of the brush
preventing splashes of water
on the floor.

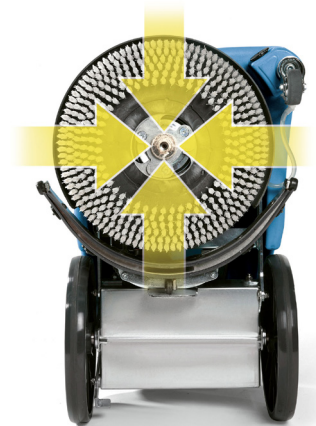

Productivity: Up to 13,000 Sq. Ft. per hour



Intelligent Design



Exceptional Engineering



Innovative Technology

Perfect Drying

The powerful suction motor is paired with a parabolic squeegee that swings around the brush and leaves the floor dry and safe.

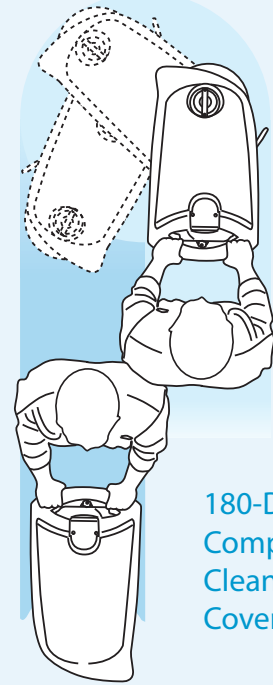
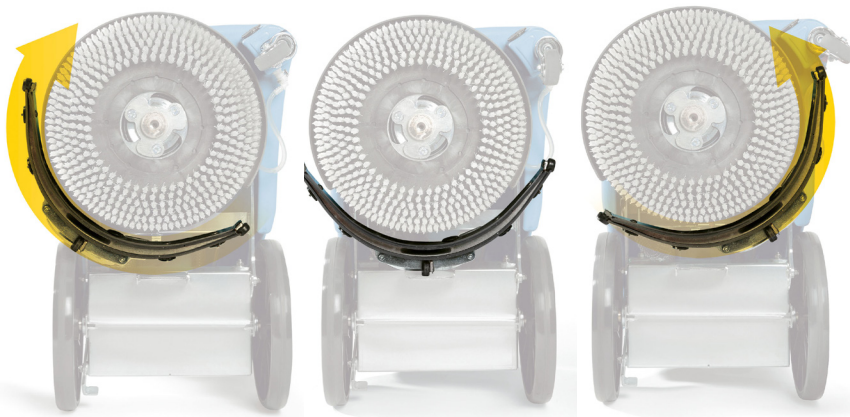

180-Degree Complete Cleaning Coverage

Simple Operation

Simple operation - simple access - minimal training - easy routine maintenance.



Foot lever lowers brush.



Quick disconnect solution supply hose.

Automatic Brush Coupling

Just a light impulse of the brush motor control is enough to couple and release the brush automatically.



Standard Onboard Charging

The B16 comes with onboard battery charging, simplifying recharging.



Better Built. Better Equipment.

Specifications		B16SC
Hillyard Item Number		HIL56002
Cleaning Path	In	16
Squeegee Width	In	18
Disc Brushes	(No.) In	(1) 16
Solution Tank	Gal	5.8
Recovery Tank	Gal	5.3
Supply/Traction	V	12/Brush Assist
Acoustic Level (Iso 11201)	Db (A)	<70
Brush Motor(s)	(No.) V/W	(1) 12/250
Vacuum Motor	V/W	12/250
Brushes RPM	RPM/Min.	140
Brush Pressure	Lb	44
Forward Speed	MPH	0 - 1.86
Gradeability	%	2
Productivity	Sq.ft/Hr	13,000
Battery Compartment Dimensions (L,H,W)	In	7.1, 9.3, 11.3
Machine Dimensions (L,H,W)	In	27.0, 37.2, 18.1
Charging System		Onboard
Machine Weight (Without Battery)	Lb	93
Continuous Run Time	Hrs	1.5
Theoretical Run Time	Hrs	3
Contents		1 - Machine 1 - Nylon Brush 1 - Pad Holder 1 - Charging Cord 1 - Owners Kit



Squeegee Replacement Guide		B16SC
Front Squeegee		HIL33041
Rear Squeegee		HIL33040

Brush and Pad Guide		B16SC
Brush(es) - Medium, 0.6MM PPL, White (Standard)		HIL33042
Pad - Red		HIL42216

Battery Recommendations - Sold Separately		Discover Energy
Type		AGM
Quantity Required		1
Size		12V / 85 Ah
Dimensions (L,W,H - Inches)		10 1/4 x 6 3/4 x 9 3/8
Weight (Each), Lbs.		53
Hillyard Item Number		DIEEV24AA



HILLYARD

 The Cleaning Resource®

PO Box 909
 St. Joseph, MO 64502
www.hillyard.com

LIT-B16-0118